

Drawings remain our exclusive property. They are entrusted only for the agreed purpose. Copies or any other reproduction, including storage, treatment and dissemination by use of electronic systems must not be made for any other than the agreed purpose. Neither originals nor reproductions may be given to or made available to third parties.

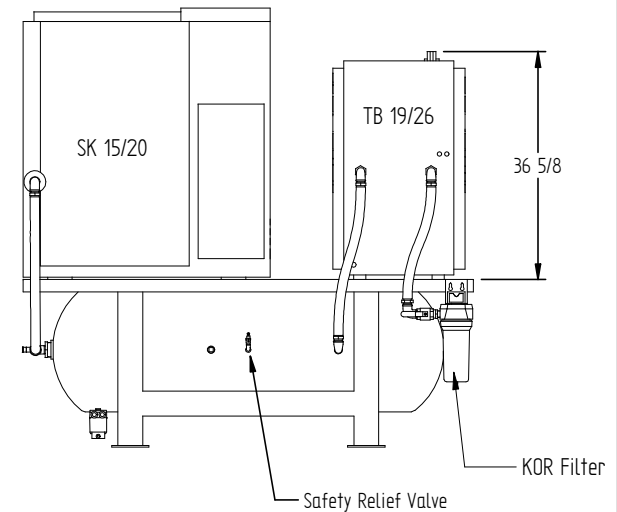
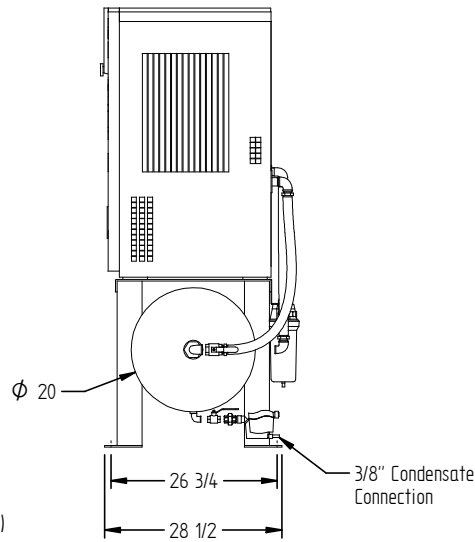
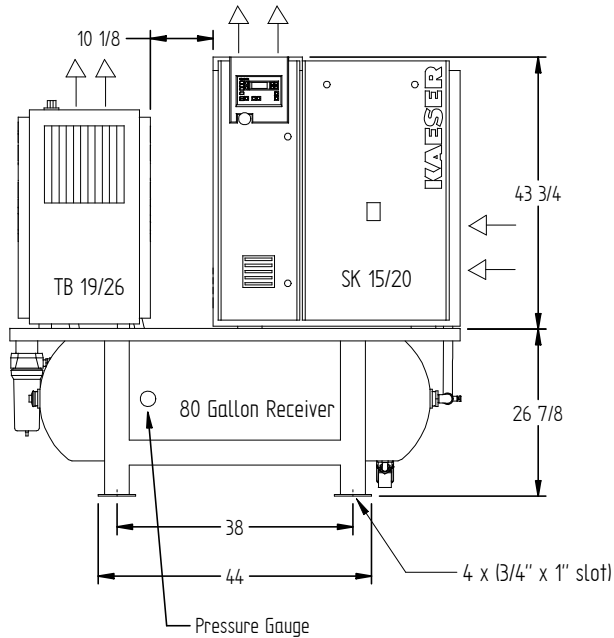
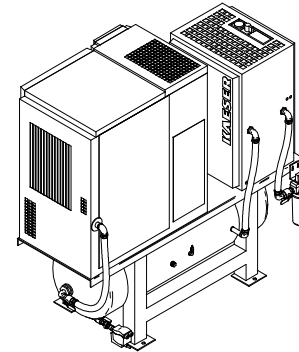
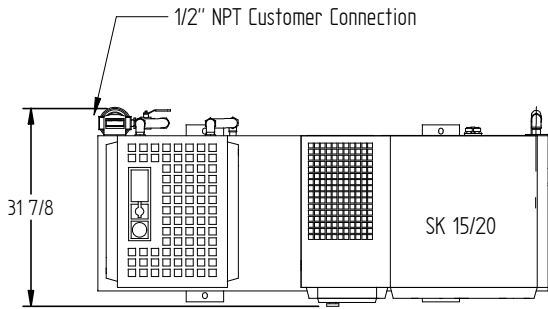

\*Package shown with optional features

All Dimensions are in inches

Ambient Temperature  
 min.: 40°F  
 max.: 115°F

<b>KAESER</b> COMPRESSORS	P + I	Scale	Date	Name
	<input type="checkbox"/> Inst.	1:20	10/24/2005	kemph
	<input checked="" type="checkbox"/>		10/20/2005	Horney
Name SK Simplex Secotec Dryer, 80 Gallon Receiver Optional Filter and Condensate Drain			Plan No. LYUS0000500	
			Page 1 of 1	

We reserve the right to make changes in the course of development. This drawing can only be modified with CAD